



[SIÈGE NATIONAL]

→ **ANFA**
 41-49 rue de la Garenne
 92313 Sèvres Cedex
 Tél. : 01.41.14.16.18 ; fax : 01.41.14.16.00
www.anfa-auto.fr

[DÉLÉGATIONS RÉGIONALES]

→ **ANFA Aquitaine, Poitou-Charentes**
 Parc technologique de Canteranne
 15 avenue de Canteranne - 33600 Pessac
 Tél. : 05.56.85.44.66 ; fax : 05.56.49.34.02
 e-mail : bordeaux@anfa-auto.fr

→ **ANFA Auvergne, Limousin**
 1 rue Képler - 63100 Clermont-Ferrand
 Tél. : 04.69.16.78.40 ; fax : 04.69.16.78.41
 e-mail : clermont@anfa-auto.fr

→ **ANFA Bretagne, Pays de la Loire**
 2 cours des Alliés - BP 40 816 - 35008 Rennes Cedex
 Tél. : 02.72.01.42.50 ; fax : 02.99.31.47.11
 e-mail : rennes@anfa-auto.fr

→ **ANFA Centre, Basse-Normandie, Haute-Normandie**
 98 rue des Hêtres - 45590 Saint Cyr en Val
 Tél. : 01.72.01.42.20 ; fax : 01.72.01.42.21
 e-mail : orleans@anfa-auto.fr

→ **ANFA Franche-Comté, Bourgogne**
 Le Forum - 5 rue Albert Thomas - 25000 Besançon
 Tél. : 03.69.32.23.20 ; fax : 03.69.32.23.21
 e-mail : besancon@anfa-auto.fr

→ **ANFA Île-de-France**
 41-49 rue de la Garenne - 92313 Sèvres Cedex
 Tél. : 01.41.14.13.07 ; fax : 01.41.14.16.56
 e-mail : sevres@anfa-auto.fr

→ **ANFA Languedoc-Roussillon, Midi-Pyrénées**
 570 cours de Dion Bouton - 30900 Nîmes
 Tél. : 04.83.07.10.20 ; fax : 04.83.07.10.21
 e-mail : nimes@anfa-auto.fr

→ **ANFA Lorraine, Alsace, Champagne-Ardenne**
 1 rue Jean-Antoine Chaptal - 57070 Metz
 Tél. : 03.69.32.23.10 ; fax : 03.69.32.23.11
 e-mail : metz@anfa-auto.fr

→ **ANFA Picardie, Nord-Pas-de-Calais**
 Immeuble Sanelec - ZAC La Vallée
 Rue Antoine Parmentier - 02100 Saint-Quentin
 Tél. : 03.61.32.14.40 ; fax : 03.23.64.30.36
 e-mail : stquentin@anfa-auto.fr

→ **ANFA Provence-Alpes-Côte d'Azur, Corse**
 Parc Club des Aygalades - Bâtiment D
 35 boulevard du Capitaine Gèze - 13014 Marseille
 Tél. : 04.83.07.10.00 ; fax : 04.91.90.97.72
 e-mail : marseille@anfa-auto.fr

→ **ANFA Rhône-Alpes**
 40 rue Hélène Boucher
 69140 Rillieux-la-Pape
 Tél. : 04.72.01.43.93 ; fax : 04.72.01.43.99
 e-mail : rillieux@anfa-auto.fr



Anglais automobile

250 mots indispensables



Camshaft - Ramp - Bumper - Multimeter - Gearbox - Windscreen - Tool trolley - Engine

LEXIQUE
TECHNIQUE

Anglais automobile
250 mots indispensables

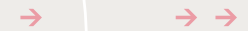

Camshaft – Ramp – Bumper – Multimeter – Gearbox – Windscreen – Tool trolley – Engine

Cette production a été réalisée, en 2008,
dans le cadre de la convention de partenariat
entre le ministère de l'Éducation nationale
et l'Association Nationale
pour la Formation Automobile.

→ **SOMMAIRE**

A. EQUIPMENT AND ACCESSORIES	2
B. WORKSHOP TOOLS	4
C. WORKSHOP HAND TOOLS	6
D. CONSUMABLES	8
E. CARBODY	10
F. PAINT WORKSHOP	12
G. VEHICLE EXTERIOR	14
H. VEHICLE INTERIOR	16
I. DASHBOARD	18
J. VEHICLE CATEGORIES	20
K. ROAD CONNEXION I (suspension, braking, pneumatics)	22
L. ROAD CONNEXION II (transmission, steering, gear, clutch) ..	24
M. UNDER THE BONNET	26
N. ENGINE	28
O. ORGANIZATION CHART	30
P. PLACES	32
LEXIQUE FRANÇAIS/ANGLAIS	36
LEXIQUE ANGLAIS/FRANÇAIS	46

A [EQUIPMENT AND ACCESSORIES]

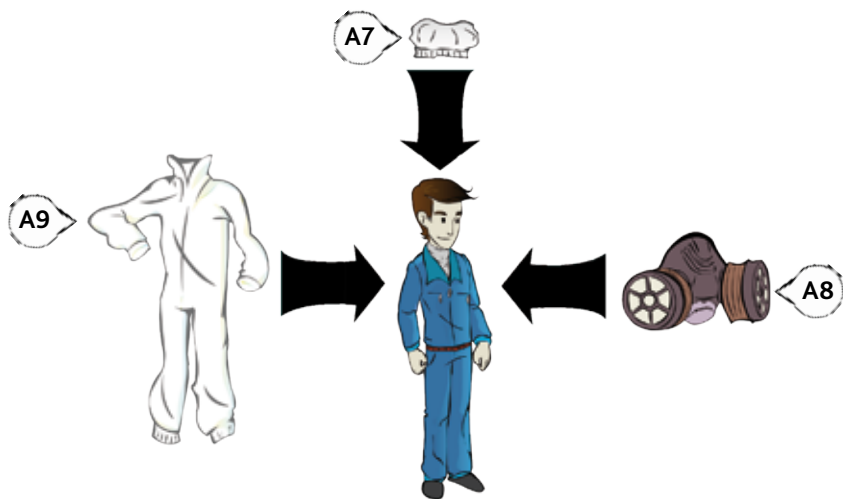
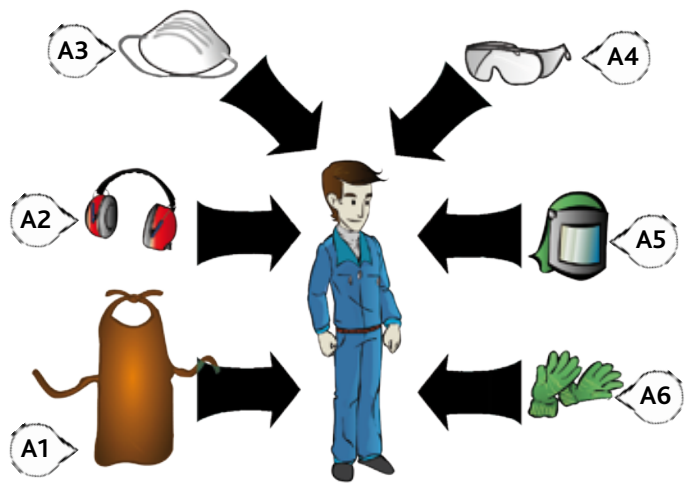

LEXIQUE ANGLAIS / FRANÇAIS

W

WINDSCREEN WASHER		lave-glace	D3
WINDSHIELD		pare-brise	G2
WING		aile	G12
WING MIRROR		rétroviseur extérieur	G3
WIPER		essuie-glace	G5
WORKSHOP		atelier	P8
WORKSHOP MANAGER		chef d'atelier	O6

LEXIQUE ANGLAIS / FRANÇAIS



T

TIMING BELT		courroie de distribution	N1
TOOL TROLLEY		servante à outils	B9
TORQUE WRENCH		clé dynamométrique	C9
TOW BALL		rotule d'attelage	G17
TOW-TRUCK		dépanneuse	J1
TRUNK		coffre	G14
TYRE		pneu	K1
TYRE PRESSURE GAUGE		manomètre	B10
TYRE-REMOVING TOOL		démonte-pneu	B7

V

VALVE		soupape	N7
VAN		utilitaire	J6
VARNISH		vernis	F12
VENTILATION		ventilation	I8

W

WAGON		pick-up	J11
WASHER		rondelle	D17
WASHER TANK		réservoir lave-glace	M1
WATER PUMP		pompe à eau	N14
WEIGHING SCALES		balance	F7
WELDING APRON		tablier de soudure	A1
WELDING MASK		masque de soudage	A5
WELDING UNIT		poste de soudure	E1
WHEEL		roue	L13
WHEEL CYLINDER		cylindre de roue	K12
WHEEL-BALANCING MACHINE		équilibreuse	B2
WINDOW WINDER		lève-vitre	H13
WINDSCREEN		pare-brise	G2

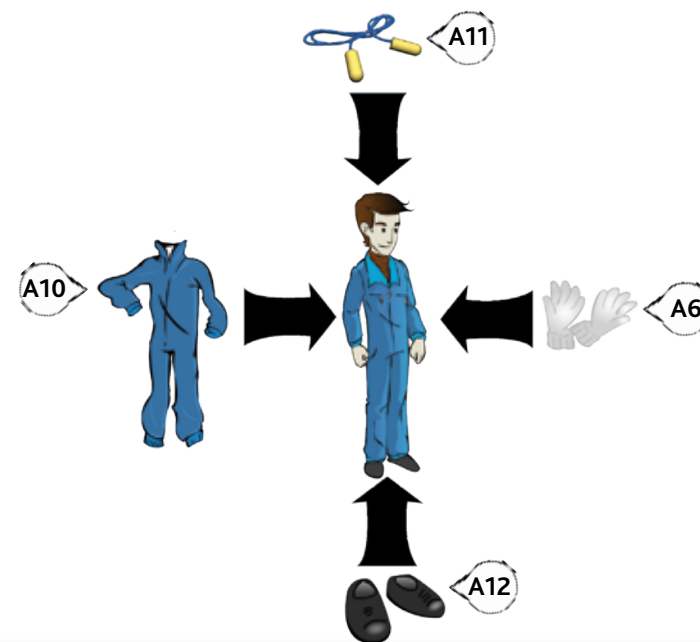

A1	W _ _ _ _ _ A _ _ _ _
A2	E _ _ P _ _ _ _ _
A3	D _ _ _ _ _ D _ _ M _ _ _
A4	S _ _ _ _ G _ _ _ _ _
A5	W _ _ _ _ M _ _ _ _
A6	G _ _ _ _ _
A7	M _ _ _ _ _
A8	R _ _ _ _ _ _ _ _
A9	D _ _ _ _ _ P _ _ _ O _ _ _ _ _
A10	O _ _ _ _ _ _
A11	E _ _ P _ _ _ _
A12	S _ _ _ _ S _ _ _ _



B1



B2

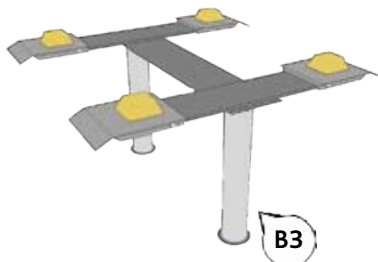

B3

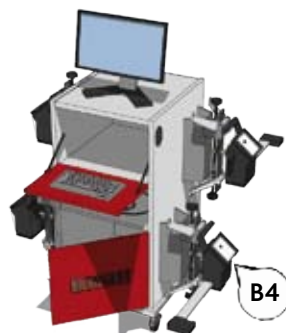

B4

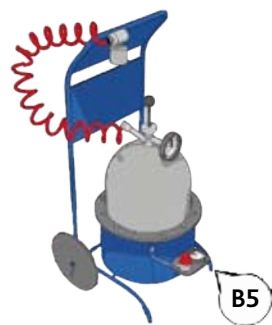

B5



B7



B8

LEXIQUE ANGLAIS / FRANÇAIS

S

SOCKET	douille à cliquet	C5
SPANNER	clé plate	C3
SPARKPLUG	bougie	D10
SPARK-PLUG SPANNER	clé à bougie	C8
SPEAKER	haut-parleur	I11
SPEEDOMETER	indicateur de vitesse	I3
SPRING	ressort	K11
STABILIZER	barre stabilisatrice	K5
STARTER	démarrreur	M10
STEEL STRING	corde à piano	E2
STEERING ALIGNMENT RACK	appareil de géométrie des trains roulants	B4
STEERING COLUMN	colonne de direction	L2
STEERING-LIQUID TANK	réservoir de liquide de direction	M6
STEERING RACK	crémaillère de direction	L1
STEERING ROD	bielle de direction	L8
STEERING WHEEL	volant	L5
STOREROOM	magasin	P4
STOREROOM WORKER	magasinier	O2
SUCTION CAP	ventouse	E19
SUN VISOR	pare-soleil	H11
SURFACE PLATE	marbre	E3
SUSPENSION ARM	bras de suspension	K7

T

TECHNICIAN	technicien	O4
TENSIONER ROLLER	galet tendeur	N2
TERMINAL LUG	cosse	D19
THERMOSTATIC SENSOR	sonde thermostatique	M8
THINNER	diluant	F5

LEXIQUE ANGLAIS / FRANÇAIS

P

PRIMER	apprêt	F10
--------	--------	-----

R

RADIATOR	radiateur	M14
----------	-----------	-----

RAMP	pont élévateur	B3
------	----------------	----

RATCHET HANDLE	cliquet	C7
----------------	---------	----

REAR MIRROR	rétroviseur intérieur	H10
-------------	-----------------------	-----

REAR SHOCK ABSORBER	amortisseur arrière	K8
---------------------	---------------------	----

REAR WINDOW	lunette arrière	G13
-------------	-----------------	-----

RECEPTION	réception	P2
-----------	-----------	----

REGISTRATION PLATE	plaque d'immatriculation	G9
--------------------	--------------------------	----

RESPIRATOR	masque de peinture	A8
------------	--------------------	----

RIM	jante	G7
-----	-------	----

RPM COUNTER	compte-tours	I4
-------------	--------------	----

S

SAFETY GLASSES	lunettes de protection	A4
----------------	------------------------	----

SAFETY SHOES	chaussures de sécurité	A12
--------------	------------------------	-----

SALOON	berline	J4
--------	---------	----

SANDING MACHINE	ponceuse	E5
-----------------	----------	----

SANDING WEDGE	cale de ponçage	E8
---------------	-----------------	----

SANDPAPER	papier à poncer	E18
-----------	-----------------	-----

SCREW	vis	D14
-------	-----	-----

SCREWDRIVER	tournevis	C12
-------------	-----------	-----

SEAT BELT	ceinture de sécurité	H12
-----------	----------------------	-----

SEAT COVER	housse	H5
------------	--------	----

SECRETARY	secrétaire	O5
-----------	------------	----

SEDAN	berline	J4
-------	---------	----

SHOWROOM	hall d'exposition	P5
----------	-------------------	----

SILENT BLOCK	silentbloc	K6
--------------	------------	----

SMALL HATCHBACK	citadine	J3
-----------------	----------	----

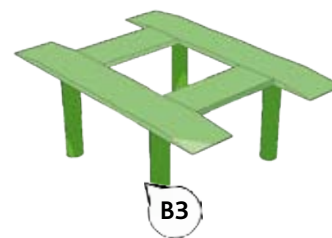

B3



B6

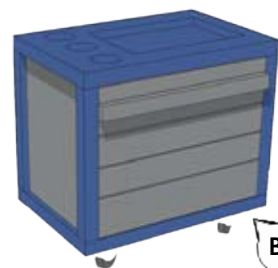

B9



B10



B11

B1	H	_	_	_	_	B	_	S	_	_
B2	W	_	-	B	_	_	M	_	_	_
B3	R	_	_	_	_	_	_	_	_	_
B4	S	_	_	A	_	_	R	_	_	_
B5	B	_	_	B	_	_	_	_	_	_
B6	D	_	_	P	_	_	C	_	_	_
B7	T	_	-	R	_	_	T	_	_	_
B8	A	_	_	D	_	_	K	_	_	_
B9	T	_	_	T	_	_	_	_	_	_
B10	T	_	_	P	_	_	G	_	_	_
B11	P	_	_	P	_	_	C	_	_	_

C [WORKSHOP HAND TOOLS]

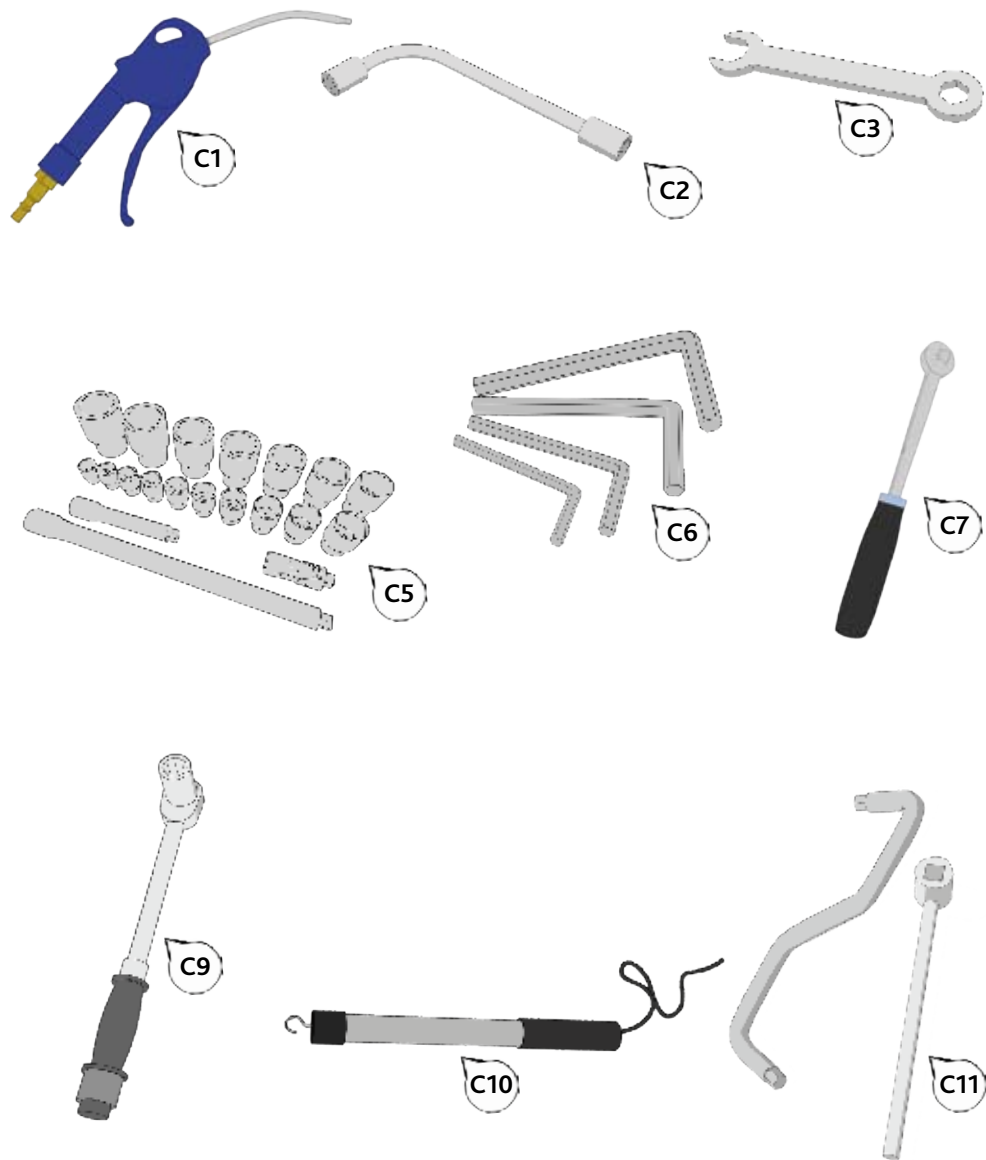

LEXIQUE ANGLAIS / FRANÇAIS



N

NAIL PULLER	tire-clou	E4
NOZZLE	buse	F8
NUT	écrou	D18

O

ODOMETER	 compteur kilométrique	I2
OIL FILTER	filtre à huile	D4
OIL GAUGE	jauge d'huile	N6
OIL INDICATOR	témoin d'huile	I1
OIL-CHANGE KEYS	clés de vidange	C11
OVERALLS	cotte	A10

P

PAINT BOOTH	cabine de peinture	F3/P1
PAINT SPRAY GUN	pistolet	F1
PAINT TIN	pot de peinture	F16
PAINTER	peintre	O10
PAIR OF PLIERS	pince	C4
PANEL REMOVER	écarteur	E12
PARTICLE FILTER	filtre à particules	D7
PASSENGER SEAT	siège passager	H14
PEOPLE CARRIER	monospace	J7
PETROL FILTER	filtre à essence	D6
PETROL INDICATOR	 témoin d'essence	I5
PETROL POLLUTION CONTROL	analyseur de gaz	B11
PETROL PUMP	pompe à essence	P11
PICK-UP VAN	 pick-up	J11
PISTON	piston	N8
PLANE	rape	E15
PRESSURE VALVE	valve	K9

LEXIQUE ANGLAIS / FRANÇAIS

H

HAMMER		marteau	C13/E11
HANDBRAKE		frein à main	H6
HANDBRAKE CABLE		câble de frein à main	K14
HARDENER		durcisseur	F4
HAZARD LIGHTS		feux de détresse	I9
HEADLIGHT		phare	G11
HEADLIGHT BEAM SETTER		réglophare	B1
HEADREST		appui-tête	H9
HOOD		capot	G4
HORN		klaxon	I7
HUBCAP		enjolveur	G16

I

IGNITION		allumage	M11
INDICATOR LEVER		commande de clignotant	I6
INSPECTION LIGHT		baladeuse	C10
INTERIOR LIGHT		plafonnier	H1

M

MALLET		maillet	E7
MASKING		marouflage	F9
MASKING PAPER		papier cache	F14
MAT		tapis de sol	H8
MECHANIC		mécanicien	O3
MILOMETER		compteur kilométrique	I2
MINIVAN		transporteur	J14
MIXER		mélangeur	F13
MOBCAP		charlotte de peinture	A7
MOTORBIKE		moto	J13
MULTIMETER		multimètre	C14

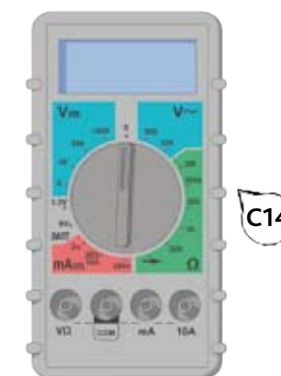
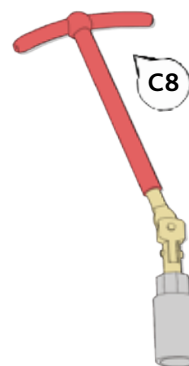
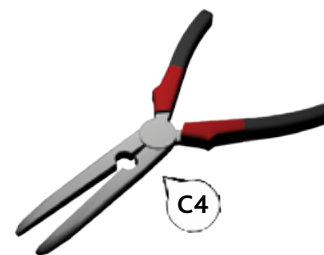

C1	A _ _ G _ _
C2	B _ _ W _ _ _ _
C3	S _ _ _ _ _
C4	P _ _ _ O _ P _ _ _ _
C5	S _ _ _ _ _
C6	A _ _ _ _ K _ _
C7	R _ _ _ _ _ H _ _ _ _
C8	S _ _ _ _ _ S _ _ _ _
C9	T _ _ _ _ W _ _ _ _
C10	I _ _ _ _ _ L _ _ _ _
C11	O _ _ - C _ _ _ _ K _ _ _
C12	S _ _ _ _ _ _ _ _ _
C13	H _ _ _ _ _
C14	M _ _ _ _ _ _ _ _

D

CONSUMABLES

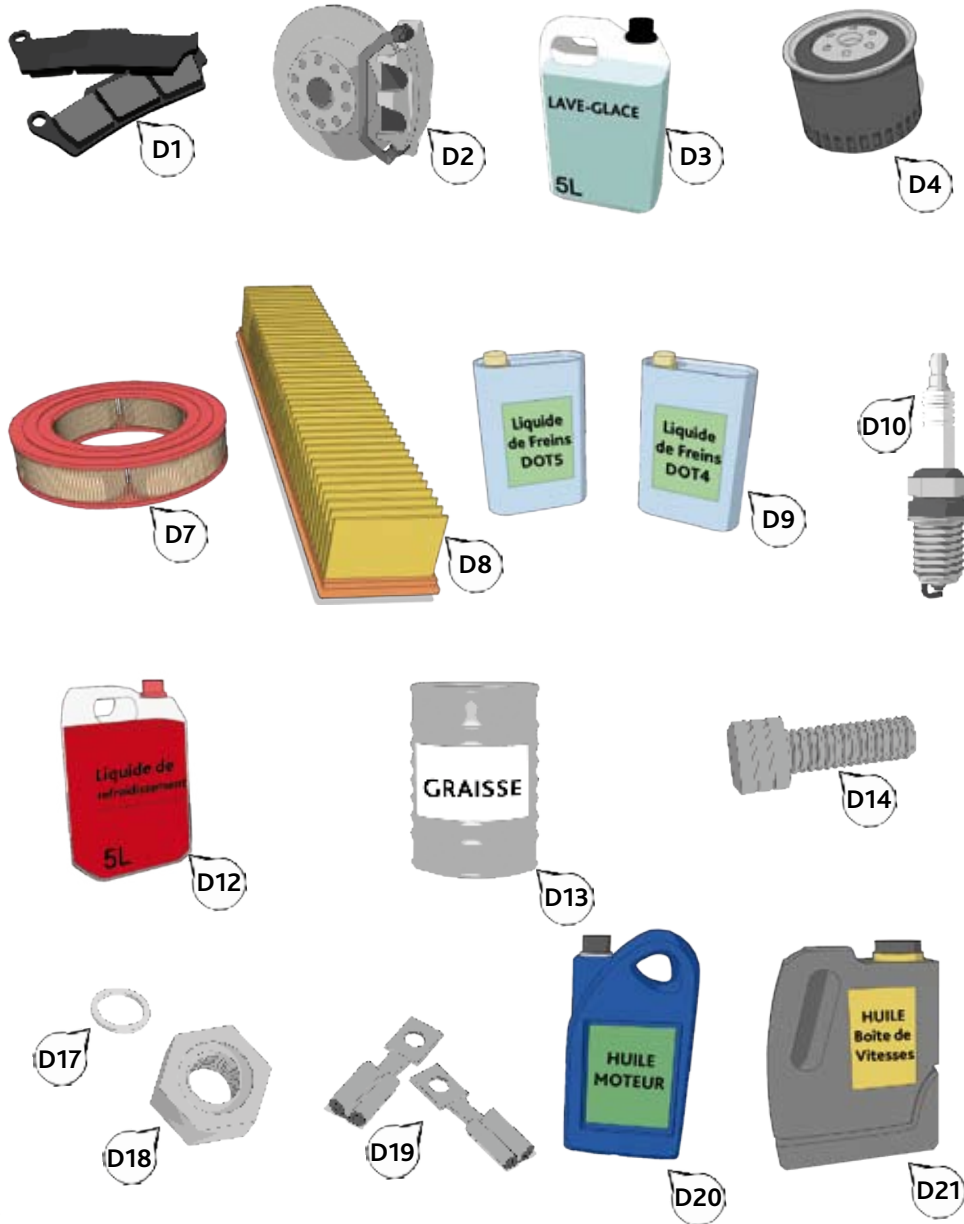

LEXIQUE ANGLAIS / FRANÇAIS

E

ELECTRONIC CONTROL BOX	boîtier électronique	M9
ENGINE	moteur	M2
ENGINE BLOCK	bloc moteur	N3
ENGINE OIL	huile moteur	D20
ESTATE CAR	break	J12
EXHAUST	collecteur d'échappement	N12

F

FAN MOTOR	motoventilateur	M12
FILLER	mastic	E13
FLEXIBLE PIPE	durite	M13
FLYWHEEL	volant moteur	N4
FOGLIGHT	antibrouillard	G8
FOUR-WHEEL DRIVE	4x4	J10
FRICTION PAD	plaquette de frein	D1
FRONT SHOCK ABSORBER	amortisseur avant	K3
FUSE	fusible	D11

G

GAS INDICATOR	 témoin d'essence	I5
GASKET	joint	D16
GEARBOX	boîte de vitesses	L14
GEARBOX LIQUID	huile de boîte de vitesses	D21
GEARSTICK	levier de vitesse	H7
GLOVE BOX	boîte à gants	H3
GLOVES	gants	A6
GREASE	graisse	D13
GRINDING MACHINE	meuleuse	E14

LEXIQUE ANGLAIS / FRANÇAIS

C

COOLANT TANK	réservoir de liquide de refroidissement	M5
COTTON WOOL	coton	F15
COUPÉ	coupé	J8
CRANKPIN	maneton	N10
CRANKSHAFT	vilebrequin	N11

D

DASHBOARD	tableau de bord	H2
DEGREASING AGENT	dégraissant	F6
DE-ICING	dégivrage	I10
DIAPHRAGM	diaphragme	L4
DIESEL FILTER	filtre à gasoil	D6
DIESEL POLLUTION CONTROL	opacimètre	D5
DIRECTION INDICATOR	flecteur de direction	L9
DISC BRAKE	disque de frein	D2
DISPOSABLE DUST MASK	masque à poussière jetable	A3
DISPOSABLE PAINT OVERALLS	combinaison de peinture jetable	A9
DOOR	portière	G15
DOOR HANDLE	poignée de portière	G6
DRILL	perceuse	E9
DRILL BIT	foret	E10
DRIVE SHAFT	arbre de transmission	L12
DRIVER'S SEAT	siège conducteur	H15
DUSTSEAL	soufflet de transmission	L11

E

EAR PLUGS	bouchons anti-bruit	A11
EAR PROTECTORS	casque	A2
ELECTRICAL WIRING	faisceau électrique	M15

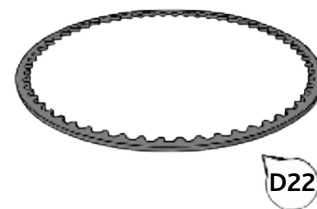
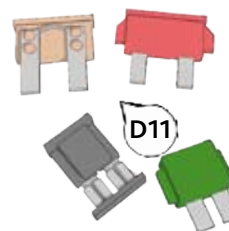
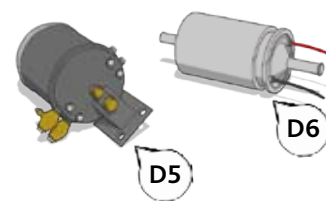

D1	F _ _ _ _ _ P _ _
D2	D _ _ _ B _ _ _
D3	W _ _ _ _ _ W _ _ _ _
D4	O _ _ F _ _ _ _
D5	D _ _ _ _ F _ _ _ _
D6	P _ _ _ _ F _ _ _ _
D7	P _ _ _ _ _ F _ _ _ _
D8	A _ _ F _ _ _ _
D9	B _ _ _ L _ _ _ _
D10	S _ _ _ _ _ _ _
D11	F _ _ _
D12	C _ _ _ _ _ _
D13	G _ _ _ _ _
D14	S _ _ _ _
D15	B _ _ _
D16	G _ _ _ _ _
D17	W _ _ _ _
D18	N _ _
D19	T _ _ _ _ _ _ L _ _
D20	E _ _ _ _ _ O _ _
D21	G _ _ _ _ _ L _ _ _ _
D22	B _ _ _

E — [CARBODY] —

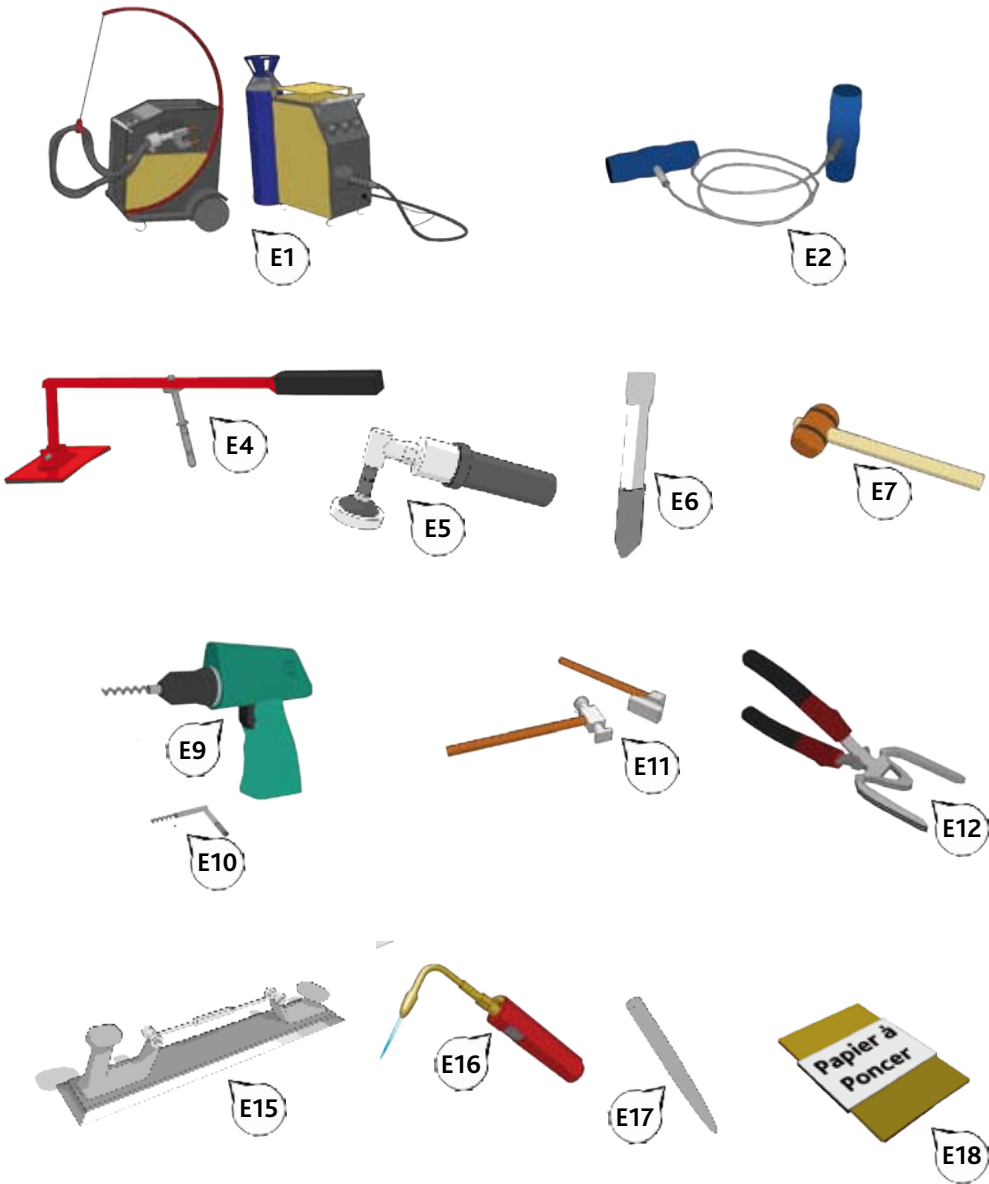

LEXIQUE ANGLAIS / FRANÇAIS

B

BOSS	gérant	O8
BOSS'S OFFICE	bureau du gérant	P3
BOX WRENCH	clé à pipe	C2
BRAKE BLEEDER	appareil de purgeur de freins	B5
BRAKE CALIPER	étrier	K10
BRAKE LIQUID	liquide de frein	D9
BRAKE-LIQUID PIPE	canalisation de liquide frein	K13
BRAKE PEDAL	pédale de frein	I13
BRAKE-LIQUID TANK	réservoir de liquide de frein	M3
BUMPER	pare-chocs	G10

C

CAMSHAFT	arbre à cames	N5
CAR RADIO	autoradio	I17
CARWASH	piste de lavage	P7
CATALYTIC CONVERTOR	pot catalytique	N13
CENTRE PUNCH	pointeau	E17
CHANGING ROOMS	vestiaires	P10
CHISEL	burin	E6
CIGAR LIGHTER	allume-cigare	I15
CLUTCH CABLE	câble d'embrayage	L7
CLUTCH DRIVEN PLATE	disque d'embrayage	L3
CLUTCH PEDAL	pédale d'embrayage	I12
CLUTCH STOP	butée d'embrayage	L6
COACH	car de tourisme	J2
COAT OF PAINT	couche de peinture	F11
COFFEE MACHINE	machine à café	P6
CONNECTING ROD	bielle	N9
COOLANT	liquide de refroidissement	D12

LEXIQUE ANGLAIS / FRANÇAIS

A

ACCELERATOR PEDAL	pédale d'accélérateur	I14
ACCOUNTANT	comptable	O7
ADHESIVE TAPE	ruban adhésif	F2
AERIAL	antenne	G1
AIR CONDITIONING	climatisation	I16
AIR FILTER	filtre à air	D8
AIR GUN	soufflette	C1
ALLEN KEY	clé allen	C6
ALTERNATOR	alternateur	M7
APPRENTICE	apprenti	O1
ARMREST	accoudoir	H4
ARTICULATED LORRY	semi-remorque	J5
AUTOMOTIVE DIAGNOSTICS KIT	appareil de diagnostic	B8
AXLE	fusée	K4

B

BACK SHELF	plage arrière	H16
BALL JOINT	rotule	L10
BATTERY	batterie	M4
BEARING	roulement	K2
BELT	courroie	D22
BICYCLE	vélo	J9
BLOWPIPE	chalumeau	E16
BODY WORKSHOP	atelier de carrosserie	P9
BODYWORKER	carrossier	O9
BOLT	boulon	D15
BONNET	capot	G4
BOOT	coffre	G14

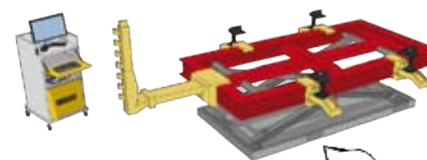

E3



E8



E13



E14



E19

E1	W _ _ _ _ _ U _ _ _
E2	S _ _ _ _ S _ _ _ _
E3	S _ _ _ _ P _ _ _ _
E4	N _ _ _ P _ _ _ _
E5	S _ _ _ _ M _ _ _ _
E6	C _ _ _ _
E7	M _ _ _ _
E8	S _ _ _ _ W _ _ _ _
E9	D _ _ _ _
E10	D _ _ _ B _ _
E11	H _ _ _ _
E12	P _ _ _ R _ _ _ _
E13	F _ _ _ _
E14	G _ _ _ _ M _ _ _ _
E15	P _ _ _ _
E16	B _ _ _ _
E17	C _ _ _ P _ _ _
E18	S _ _ _ _
E19	S _ _ _ C _ _

F [PAINT WORKSHOP]

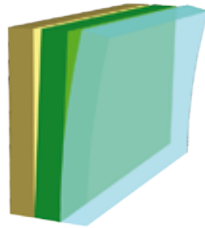
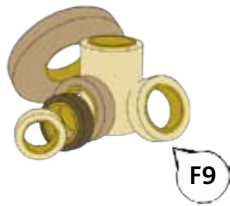
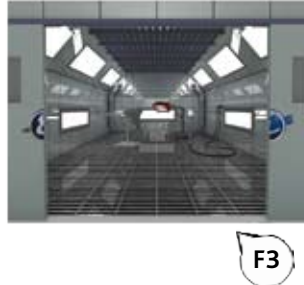
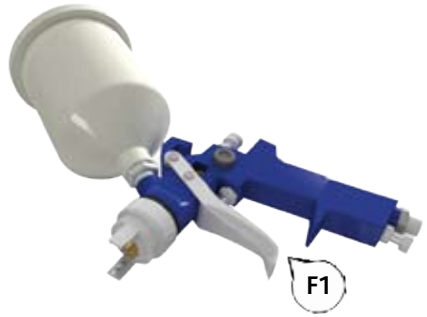

- F10 apprêt
- F11 couche de peinture
- F12 vernis

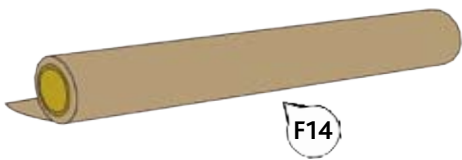

LEXIQUE FRANÇAIS / ANGLAIS

V

VOLANT MOTEUR	flywheel	N4
4X4	four-wheel drive	J10

LEXIQUE FRANÇAIS / ANGLAIS

S

SILENTBLOC	silent block		K6
SONDE THERMOSTATIQUE	thermostatic sensor		M8
SOUFFLET DE TRANSMISSION	dustseal		L11
SOUFFLETTE	air gun		C1
SOUPAPE	valve		N7

T

TABEAU DE BORD	dashboard		H2
TABLIER DE SOUDURE	welding apron		A1
TAPIS DE SOL	mat		H8
TECHNICIEN	technician		O4
TÉMOIN D'ESSENCE	petrol indicator		I5
	gas indicator		I5
TÉMOIN D'HUILE	oil indicator		I1
TIRE-CLOU	nail puller		E4
TOURNEVIS	screwdriver		C12
TRANSPORTEUR	minivan		J14

U

UTILITAIRE	van		J6
------------	-----	--	----

V

VALVE	pressure valve		K9
VÉLO	bicycle		J9
VENTILATION	ventilation		I8
VENTOUSE	suction cap		E19
VERNIS	varnish		F12
VESTIAIRES	changing rooms		P10
VILEBREQUIN	crankshaft		N11
VIS	screw		D14
VOLANT	steering wheel		L5

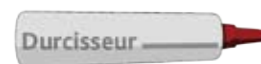

F4



F8

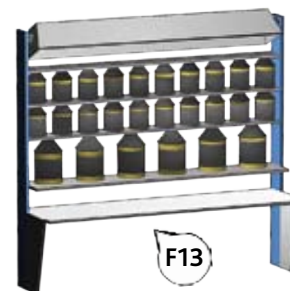

F13

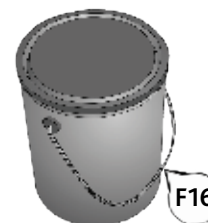

F16

F1	P _ _ _ _ S _ _ _ _ G _ _
F2	A _ _ _ _ _ _ _ T _ _ _
F3	P _ _ _ _ B _ _ _ _
F4	H _ _ _ _ _ _ _
F5	T _ _ _ _ _ _ _
F6	D _ _ _ _ _ _ _ _ A _ _ _ _
F7	W _ _ _ _ _ _ _ S _ _ _ _ _
F8	N _ _ _ _ _
F9	M _ _ _ _ _ _
F10	P _ _ _ _ _
F11	C _ _ _ O _ P _ _ _ _
F12	V _ _ _ _ _ _ _
F13	M _ _ _ _ _
F14	M _ _ _ _ _ _ P _ _ _ _
F15	C _ _ _ _ _ W _ _ _ _
F16	P _ _ _ _ T _ _

VEHICLE EXTERIOR

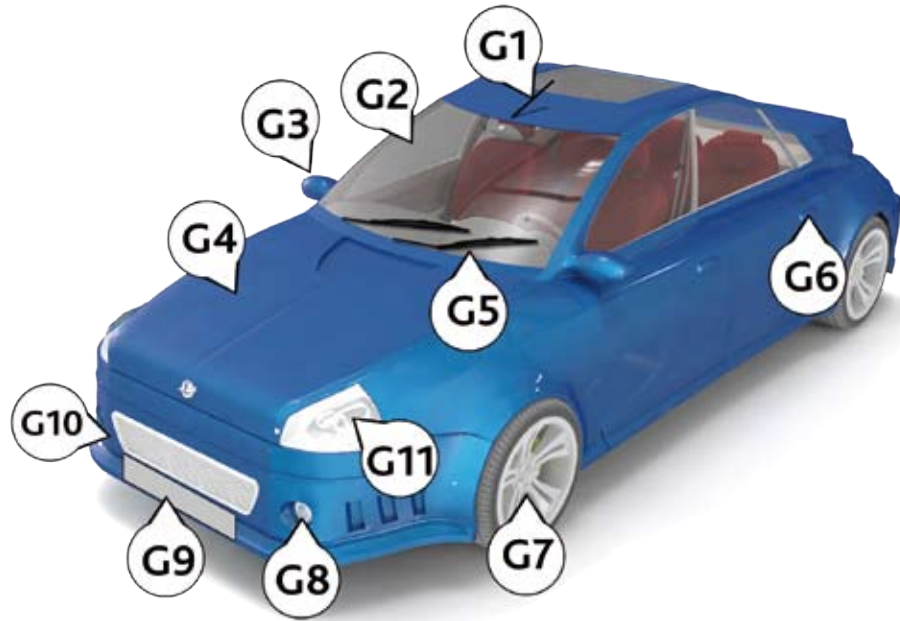

G1	A _ _ _ _ _	
G2	W _ _ _ _ _	
G2	W _ _ _ _ _	
G3	W _ _ _ M _ _ _ _	
G4	B _ _ _ _ _	
G4	H _ _ _ _	
G5	W _ _ _ _	
G6	D _ _ _ H _ _ _ _	
G7	R _ _ _	
G8	F _ _ _ _ _	
G9	R _ _ _ _ _ _ _ _ P _ _ _ _	
G10	B _ _ _ _ _	
G11	H _ _ _ _ _	

LEXIQUE FRANÇAIS / ANGLAIS

P

PORTIÈRE	door	G15
POSTE DE SOUDURE	welding unit	E1
POT CATALYTIQUE	catalytic convertor	N13
POT DE PEINTURE	paint tin	F16

R



RADIATEUR	radiator	M14
RAPE	plane	E15
RÉCEPTION	reception	P2
RÉGLOPHARE	headlight beam setter	B1
RÉSERVOIR DE LIQUIDE DE DIRECTION	steering-liquid tank	M6
RÉSERVOIR DE LIQUIDE DE FREIN	brake-liquid tank	M3
RÉSERVOIR DE LIQUIDE DE REFROIDISSEMENT	coolant tank	M5
RÉSERVOIR LAVE-GLACE	washer tank	M1
RESSORT	spring	K11
RÉTROVISEUR EXTÉRIEUR	wing mirror	G3
RÉTROVISEUR INTÉRIEUR	rear mirror	H10
RONDELLE	washer	D17
ROTULE	ball joint	L10
ROTULE D'ATTELAGE	tow ball	G17
ROUE	wheel	L13
ROULEMENT	bearing	K2
RUBAN ADHÉSIF	adhesive tape	F2

S



SECRÉTAIRE	secretary	O5
SEMI-REMORQUE	articulated lorry	J5
SERVANTE À OUTILS	tool trolley	B9
SIÈGE CONDUCTEUR	driver's seat	H15
SIÈGE PASSAGER	passenger seat	H14

LEXIQUE FRANÇAIS / ANGLAIS

P

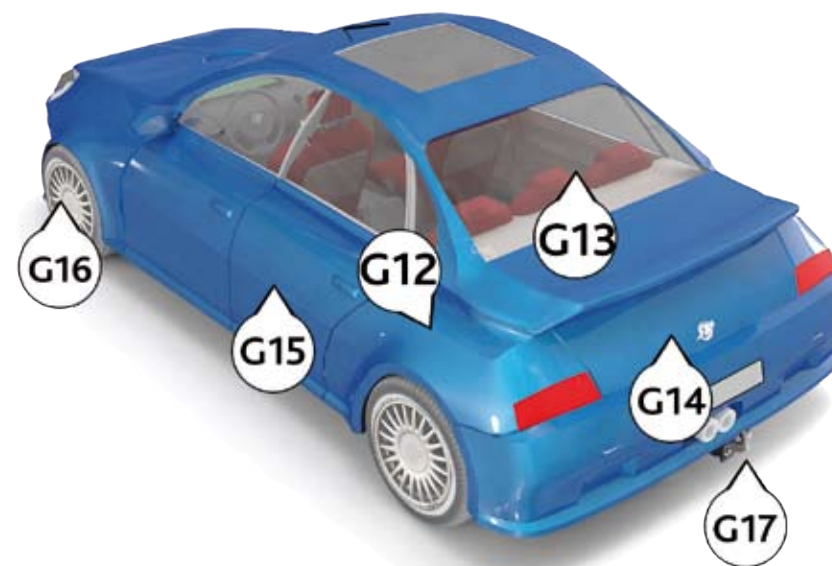
PAPIER À PONCER	sandpaper		E18
PAPIER CACHE	masking paper		F14
PARE-BRISE	windscreen		G2
	windshield		G2
PARE-CHOCS	bumper		G10
PARE-SOLEIL	sun visor		H11
PÉDALE D'ACCÉLÉRATEUR	accelerator pedal		I14
PÉDALE DE FREIN	brake pedal		I13
PÉDALE D'EMBRAYAGE	clutch pedal		I12
PEINTRE	painter		O10
PERCEUSE	drill		E9
PHARE	headlight		G11
PICK-UP	pick-up van		J11
	wagon		J11
PINCE	pair of pliers		C4
PISTE DE LAVAGE	carwash		P7
PISTOLET	paint spray gun		F1
PISTON	piston		N8
PLAFONNIER	interior light		H1
PLAGE ARRIÈRE	back shelf		H16
PLAQUE D'IMMATRICULATION	registration plate		G9
PLAQUETTE DE FREIN	friction pad		D1
PNEU	tyre		K1
POIGNÉE DE PORTIÈRE	door handle		G6
POINTEAU	centre punch		E17
POMPE À EAU	water pump		N14
POMPE À ESSENCE	petrol pump		P11
PONCEUSE	sanding machine		E5
PONT ÉLÉVATEUR	ramp		B3



G12	W _ _ _ _	
G13	R _ _ _ W _ _ _ _ _	
G14	B _ _ _	
G14	T _ _ _ _	
G15	D _ _ _	
G16	H _ _ _ _ _	
G17	T _ _ B _ _ _	

H [VEHICLE INTERIOR]

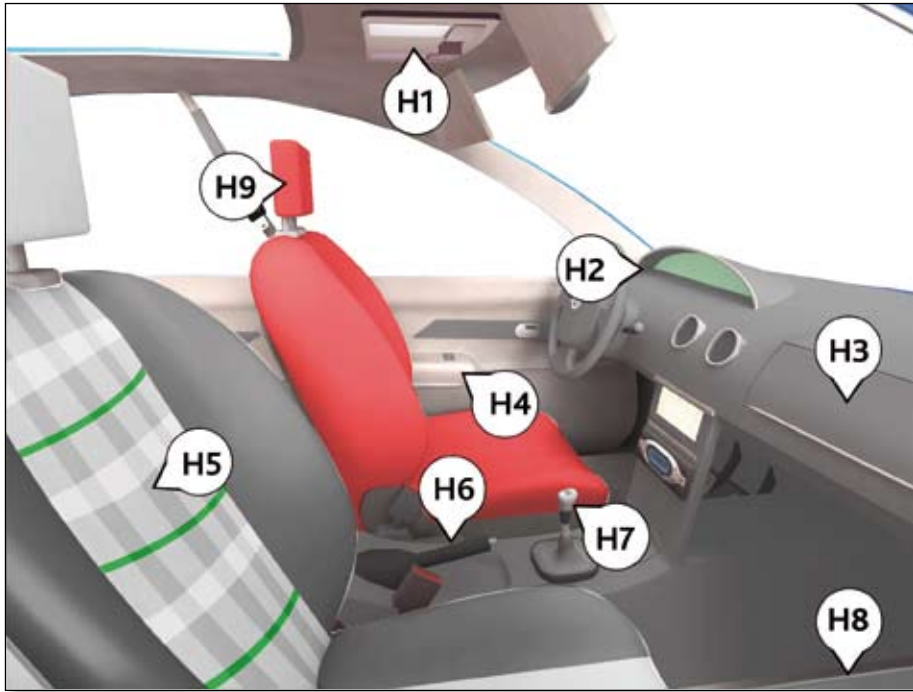

H1	I _ _ _ _ _ L _ _ _ _
H2	D _ _ _ _ _
H3	G _ _ _ _ B _ _
H4	A _ _ _ _ _
H5	S _ _ _ _ C _ _ _ _
H6	H _ _ _ _ _
H7	G _ _ _ _ _
H8	M _ _
H9	H _ _ _ _ _

LEXIQUE FRANÇAIS / ANGLAIS		
L		
LIQUIDE DE FREIN	brake liquid	D9
LIQUIDE DE REFROIDISSEMENT	coolant	D12
LUNETTE ARRIÈRE	rear window	G13
LUNETTES DE PROTECTION	safety glasses	A4
M		
MACHINE À CAFÉ	coffee machine	P6
MAGASIN	storeroom	P4
MAGASINIER	storeroom worker	O2
MAILLET	mallet	E7
MANETON	crankpin	N10
MANOMÈTRE	tyre pressure gauge	B10
MARBRE	surface plate	E3
MAROUFLAGE	masking	F9
MARTEAU	hammer	C13/E11
MASQUE À POUSSIÈRE JETABLE	disposable dust mask	A3
MASQUE DE PEINTURE	respirator	A8
MASQUE DE SOUDAGE	welding mask	A5
MASTIC	filler	E13
MÉCANICIEN	mechanic	O3
MÉLANGEUR	mixer	F13
MEULEUSE	grinding machine	E14
MONOSPACE	people carrier	J7
MOTEUR	engine	M2
MOTO	motorbike	J13
MOTOVENTILATEUR	fan motor	M12
MULTIMÈTRE	multimeter	C14
O		
OPACIMÈTRE	diesel pollution control	B6

LEXIQUE FRANÇAIS / ANGLAIS

F

FILTRE À PARTICULES	particle filter	D7
FLECTEUR DE DIRECTION	direction indicator	L9
FORET	drill bit	E10
FREIN À MAIN	handbrake	H6
FUSÉE	axle	K4
FUSIBLE	fuse	D11

G

GALET TENDEUR	tensioner roller	N2
GANTS	gloves	A6
GÉRANT	boss	O8
GRAISSE	grease	D13

H

HALL D'EXPOSITION	showroom	P5
HAUT-PARLEUR	speaker	I11
HOUSSE	seat cover	H5
HUILE DE BOÎTE DE VITESSES	gearbox liquid	D21
HUILE MOTEUR	engine oil	D20

I

INDICATEUR DE VITESSE	speedometer	I3
-----------------------	-------------	----

J

JANTE	rim	G7
JAUGE D'HUILE	oil gauge	N6
JOINT	gasket	D16

K

KLAXON	horn	I7
--------	------	----

L

LAVE-GLACE	windscreen washer	D3
LÈVE-VITRE	window winder	H13
LEVIER DE VITESSE	gearstick	H7

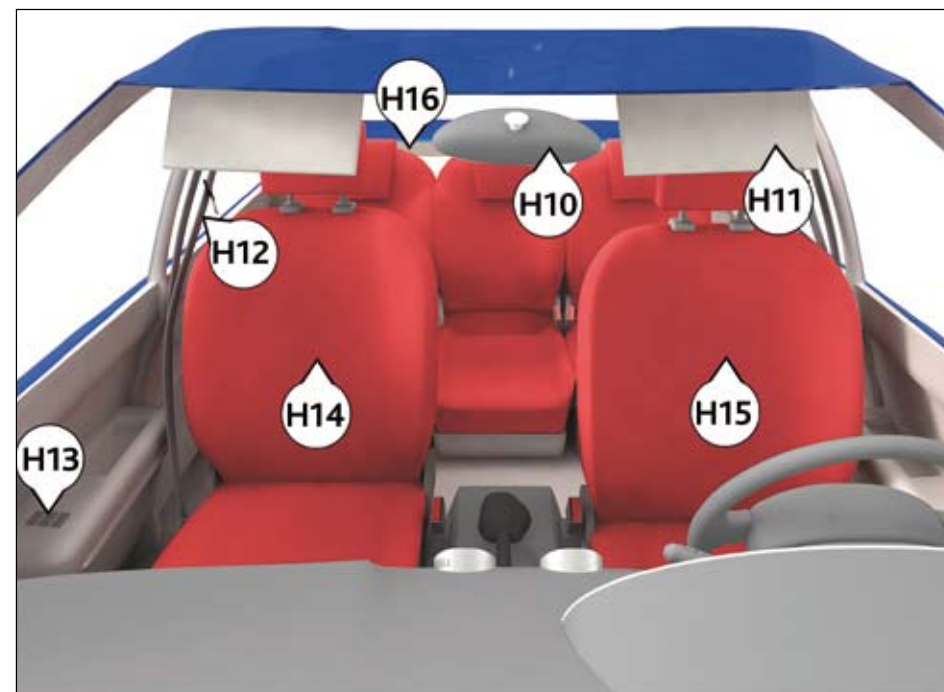

H10	R _ _ _ M _ _ _ _ _
H11	S _ _ _ V _ _ _ _ _
H12	S _ _ _ B _ _ _ _
H13	W _ _ _ _ _ W _ _ _ _ _
H14	P _ _ _ _ _ _ _ _ S _ _ _ _
H15	D _ _ _ _ _ 'S S _ _ _ _
H16	B _ _ _ S _ _ _ _ _

I [DASHBOARD]

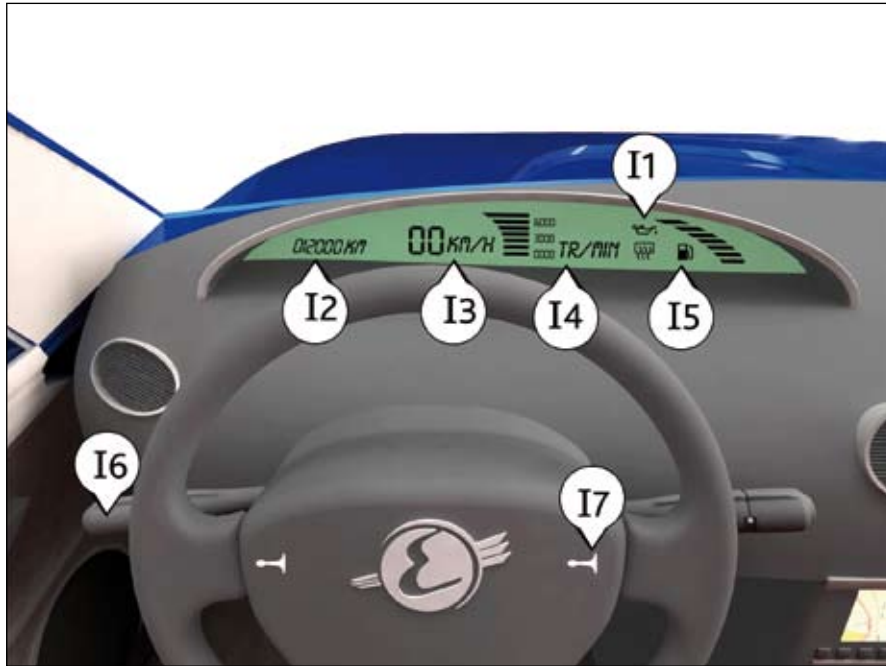

I1	O _ _ I _ _ _ _	
I2	M _ _ _ _ _	
I2	O _ _ _ _ _	
I3	S _ _ _ _ _	
I4	R _ _ C _ _ _	
I5	P _ _ _ _ I _ _ _	
I5	G _ _ I _ _ _ _	
I6	I _ _ _ _ _ L _ _ _	
I7	H _ _ _	

LEXIQUE FRANÇAIS / ANGLAIS

C

CRÉMAILLÈRE DE DIRECTION	steering rack	L1
CYLINDRE DE ROUE	wheel cylinder	K12

D

DÉGIVRAGE	de-icing	I10
DÉGRAISSANT	degreasing agent	F6
DÉMARREUR	starter	M10
DÉMONTE-PNEU	tyre-removing tool	B7
DÉPANNEUSE	tow-truck	J1
DIAPHRAGME	diaphragm	L4
DILUANT	thinner	F5
DISQUE D'EMBRAYAGE	clutch driven plate	L3
DISQUE DE FREIN	disc brake	D2
DOUILLE À CLIQUET	socket	C5
DURCISSEUR	hardener	F4
DURITE	flexible pipe	M13

E





ÉCARTEUR	panel remover	E12
ÉCROU	nut	D18
ENJOLIVEUR	hubcap	G16
ÉQUILIBREUSE	wheel-balancing machine	B2
ESSUIE-GLACE	wiper	G5
ÉTRIER	brake caliper	K10

F

FAISCEAU ÉLECTRIQUE	electrical wiring	M15
FEUX DE DÉTRESSE	hazard lights	I9
FILTRE À AIR	air filter	D8
FILTRE À ESSENCE	petrol filter	D6
FILTRE À GASOIL	diesel filter	D5
FILTRE À HUILE	oil filter	D4

LEXIQUE FRANÇAIS / ANGLAIS

C

CHAUSSURES DE SÉCURITÉ	safety shoes		A12
CHEF D'ATELIER	workshop manager		O6
CITADINE	small hatchback		J3
CLÉ À BOUGIE	spark-plug spanner		C8
CLÉ À PIPE	box wrench		C2
CLÉ ALLEN	allen key		C6
CLÉS DE VIDANGE	oil-change keys		C11
CLÉ DYNAMOMÉTRIQUE	torque wrench		C9
CLÉ PLATE	spanner		C3
CLIMATISATION	air conditioning		I16
CLIQUET	ratchet handle		C7
COFFRE	boot		G14
	trunk		G14
COLLECTEUR D'ÉCHAPPEMENT	exhaust		N12
COLONNE DE DIRECTION	steering column		L2
COMBINAISON DE PEINTURE JETABLE	disposable paint overalls		A9
COMMANDE DE CLIGNOTANT	indicator lever		I6
COMPTABLE	accountant		O7
COMPTE-TOURS	rpm counter		I4
COMPTEUR KILOMÉTRIQUE	milometer		I2
	odometer		I2
CORDE À PIANO	steel string		E2
COSSE	terminal lug		D19
COTON	cotton wool		F15
COTTE	overalls		A10
COUCHE DE PEINTURE	coat of paint		F11
COUPÉ	coupé		J8
COURROIE	belt		D22
COURROIE DE DISTRIBUTION	timing belt		N1

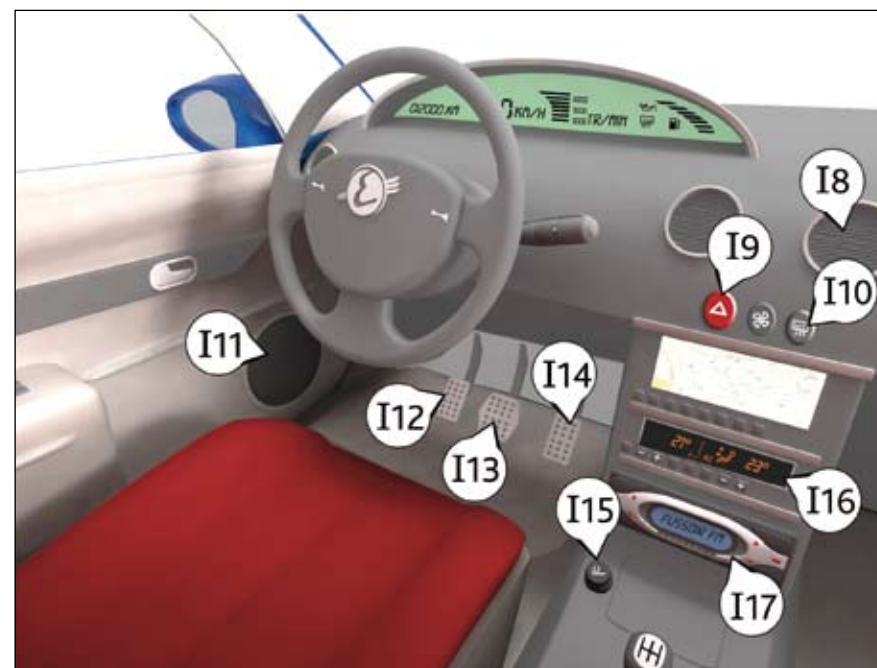

I8	V _ _ _ _ _
I9	H _ _ _ L _ _ _
I10	D _ - I _ _ _
I11	S _ _ _ _ _
I12	C _ _ _ _ P _ _ _
I13	B _ _ _ P _ _ _
I14	A _ _ _ _ _ P _ _ _
I15	C _ _ _ L _ _ _
I16	A _ _ C _ _ _ _ _
I17	C _ _ R _ _ _

VEHICLE CATEGORIES





LEXIQUE FRANÇAIS / ANGLAIS

B

BIELLE	connecting rod	N9
BIELLETTE DE DIRECTION	steering rod	L8
BLOC MOTEUR	engine block	N3
BOÎTE À GANTS	glove box	H3
BOÎTE DE VITESSES	gearbox	L14
BOÎTIER ÉLECTRONIQUE	electronic control box	M9
BOUCHONS ANTI-BRUIT	ear plugs	A11
BOUGIE	sparkplug	D10
BOULON	bolt	D15
BRAS DE SUSPENSION	suspension arm	K7
BREAK	estate car	J12
BUREAU DU GÉRANT	boss's office	P3
BURIN	chisel	E6
BUSE	nozzle	F8
BUTÉE D'EMBRAYAGE	clutch stop	L6

C



CABINE DE PEINTURE	paint booth	F3/P1
CÂBLE D'EMBRAYAGE	clutch cable	L7
CÂBLE DE FREIN À MAIN	handbrake cable	K14
CALE DE PONÇAGE	sanding wedge	E8
CANALISATION DE LIQUIDE FREIN	brake-liquid pipe	K13
CAPOT	bonnet	 G4
	hood	 G4
CAR DE TOURISME	coach	J2
CARROSSIER	bodyworker	O9
CASQUE	ear protectors	A2
CEINTURE DE SÉCURITÉ	seat belt	H12
CHALUMEAU	blowpipe	E16
CHARLOTTE DE PEINTURE	mobcap	A7

LEXIQUE FRANÇAIS / ANGLAIS

A

ACCOUDOIR	armrest		H4
AILE	wing		G12
ALLUMAGE	ignition		M11
ALLUME-CIGARE	cigar lighter		I15
ALTERNATEUR	alternator		M7
AMORTISSEUR ARRIÈRE	rear shock absorber		K8
AMORTISSEUR AVANT	front shock absorber		K3
ANALYSEUR DE GAZ	petrol pollution control		B11
ANTENNE	aerial		G1
ANTIBROUILLARD	foglight		G8
APPAREIL DE DIAGNOSTIC	automotive diagnostics kit		B8
APPAREIL DE GÉOMÉTRIE DES TRAINS ROULANTS	steering alignment rack		B4
APPAREIL DE PURGEUR DE FREINS	brake bleeder		B5
APPRENTI	apprentice		O1
APPRÊT	primer		F10
APPUI-TÊTE	headrest		H9
ARBRE À CAMES	camshaft		N5
ARBRE DE TRANSMISSION	drive shaft		L12
ATELIER	workshop		P8
ATELIER DE CARROSSERIE	body workshop		P9
AUTORADIO	car radio		I17

B

BALADEUSE	inspection light		C10
BALANCE	weighing scales		F7
BARRE STABILISATRICE	stabilizer		K5
BATTERIE	battery		M4
BERLINE	saloon		J4
	sedan		J4



J4



J7





J10



J13



J14

J1	T _ _ - T _ _ _ _	
J2	C _ _ _ _	
J3	S _ _ _ _ H _ _ _ _ _	
J4	S _ _ _ _	
J4	S _ _ _ _	
J5	A _ _ _ _ _ _ _ _ _ L _ _ _ _	
J6	V _ _	
J7	P _ _ _ _ C _ _ _ _ _	
J8	C _ _ _ _	
J9	B _ _ _ _ _	
J10	F _ _ _ - W _ _ _ _ D _ _ _ _	
J11	P _ _ _ - U _ V _ _	
J11	W _ _ _ _	
J12	E _ _ _ _ C _ _	
J13	M _ _ _ _ _ _	
J14	M _ _ _ _ _	

K [ROAD CONNEXION I (suspension, braking, pneumatics)]

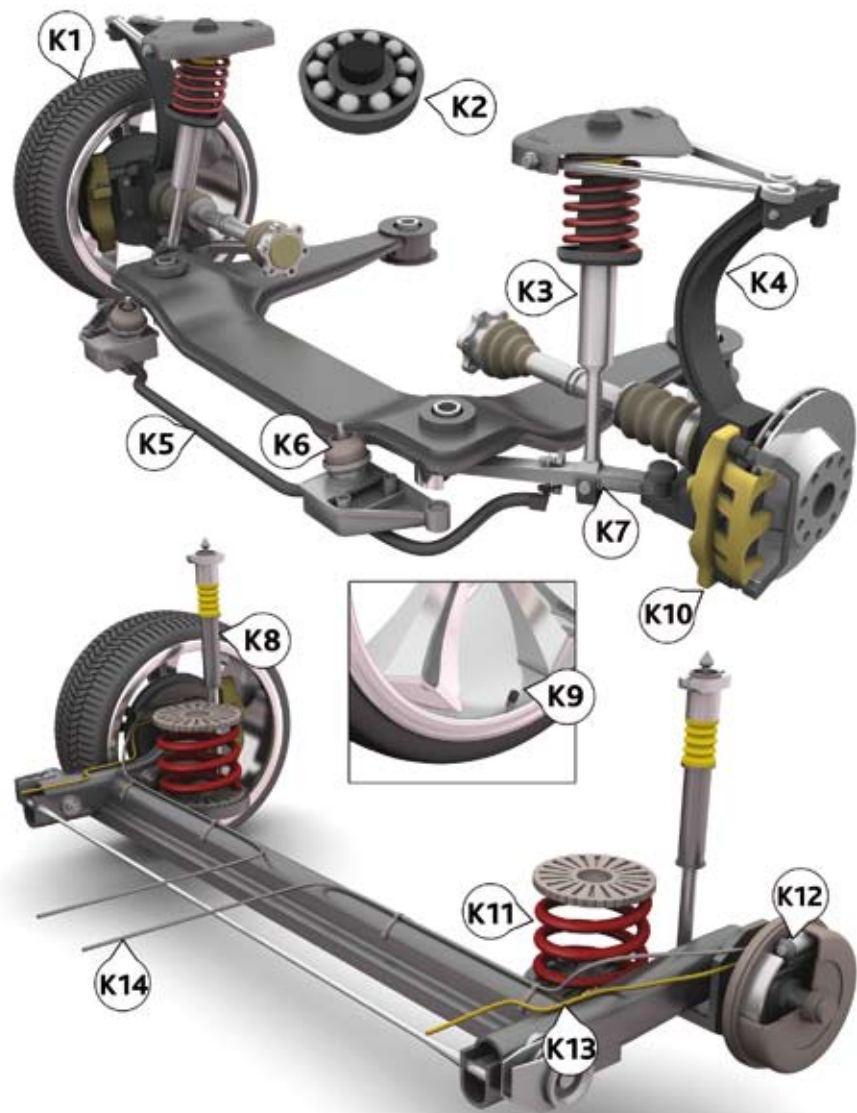

→ LEXIQUE

FRANÇAIS / ANGLAIS.....	36
ANGLAIS / FRANÇAIS.....	46

K1	T _ _ _
K2	B _ _ _ _ _ _
K3	F _ _ _ _ S _ _ _ _ A _ _ _ _ _ _
K4	A _ _ _
K5	S _ _ _ _ _ _ _ _
K6	S _ _ _ _ _ B _ _ _ _
K7	S _ _ _ _ _ _ _ _ A _ _
K8	R _ _ _ S _ _ _ _ A _ _ _ _ _ _
K9	P _ _ _ _ _ V _ _ _ _
K10	B _ _ _ _ C _ _ _ _ _
K11	S _ _ _ _ _
K12	W _ _ _ _ C _ _ _ _ _ _
K13	B _ _ _ _ - L _ _ _ _ _ P _ _ _
K14	H _ _ _ _ _ _ _ C _ _ _ _

L [**ROAD CONNEXION II**
(transmission, steering, gear, clutch)

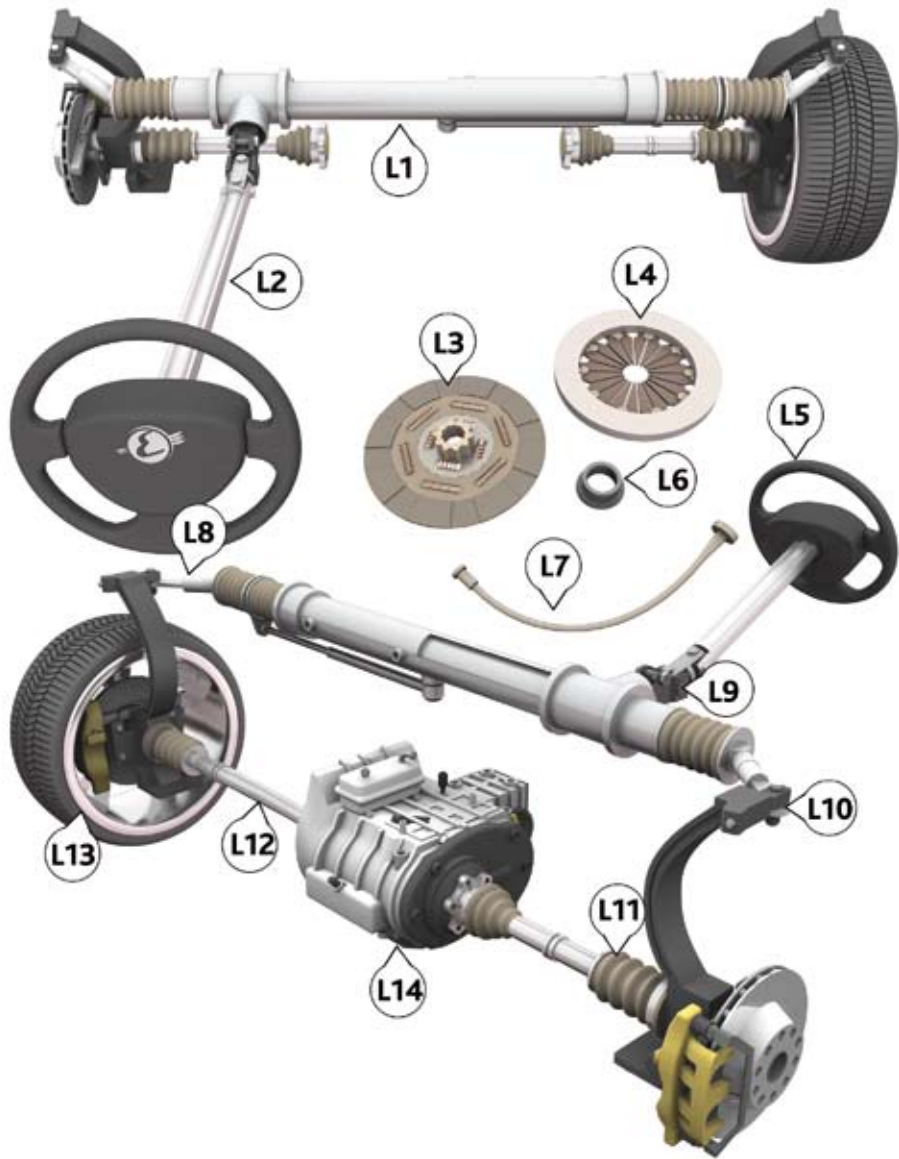

P1	P _ _ _ _ B _ _ _ _
P2	R _ _ _ _ _ _ _ _
P3	B _ _ _ ' S O _ _ _ _
P4	S _ _ _ _ _ _ _ _
P5	S _ _ _ _ _ _ _ _
P6	C _ _ _ _ M _ _ _ _
P7	C _ _ _ _ _
P8	W _ _ _ _ _ _ _ _
P9	B _ _ _ W _ _ _ _ _
P10	C _ _ _ _ _ R _ _ _ _
P11	P _ _ _ _ P _ _ _ _

P [PLACES]

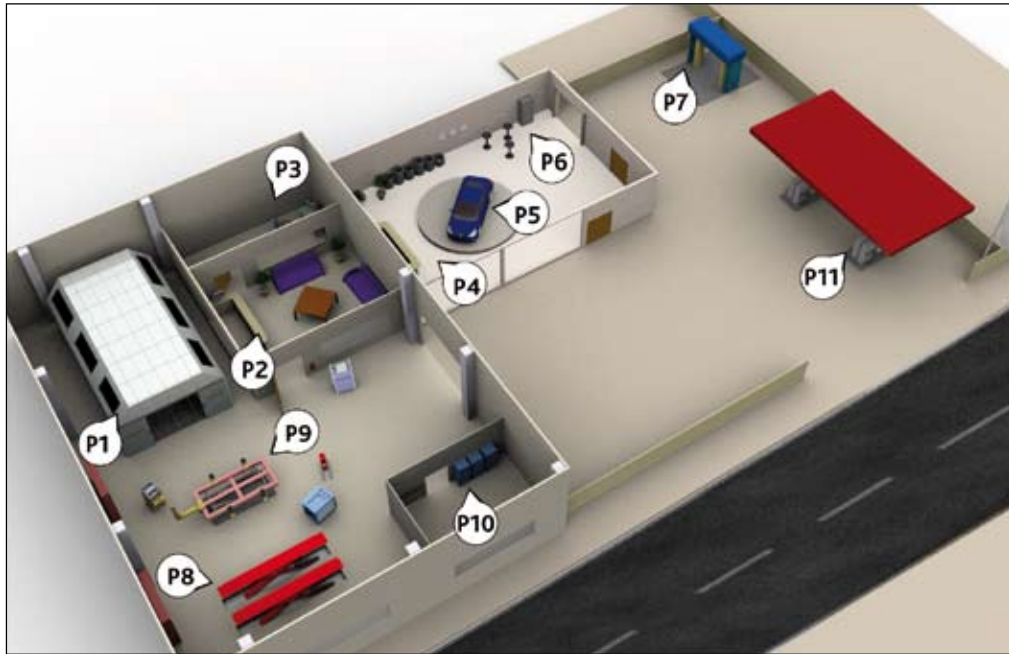

L1	S _ _ _ _ _ R _ _ _
L2	S _ _ _ _ _ C _ _ _ _ _
L3	C _ _ _ _ _ D _ _ _ _ _ P _ _ _ _
L4	D _ _ _ _ _
L5	S _ _ _ _ _ W _ _ _ _
L6	C _ _ _ _ _ S _ _ _
L7	C _ _ _ _ _ C _ _ _ _
L8	S _ _ _ _ _ R _ _ _
L9	D _ _ _ _ _ I _ _ _ _ _
L10	B _ _ _ _ J _ _ _ _
L11	D _ _ _ _ _
L12	D _ _ _ _ S _ _ _ _
L13	W _ _ _ _
L14	G _ _ _ _ _

M [UNDER THE BONNET]

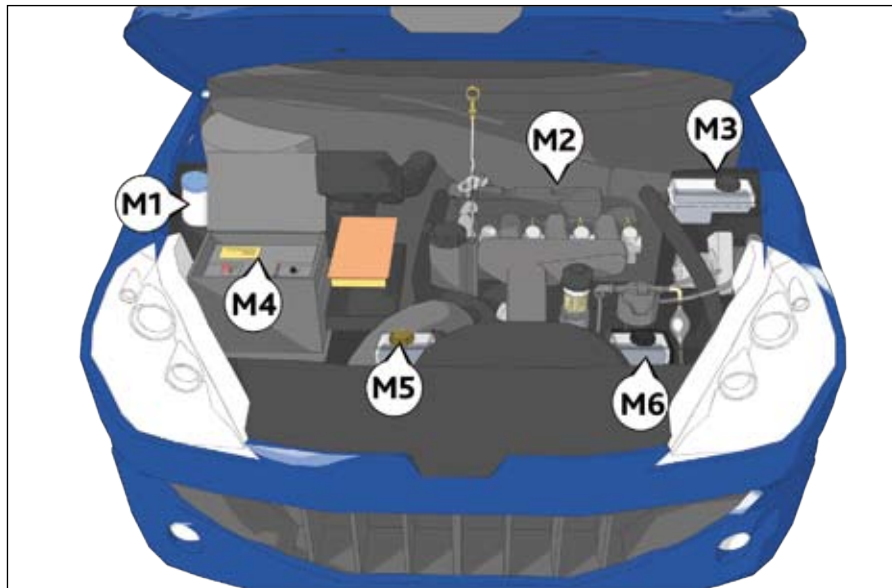

M1	W _ _ _ _ T _ _ _
M2	E _ _ _ _
M3	B _ _ _ - L _ _ _ T _ _ _
M4	B _ _ _ _
M5	C _ _ _ _ T _ _ _
M6	S _ _ _ _ - L _ _ _ T _ _ _

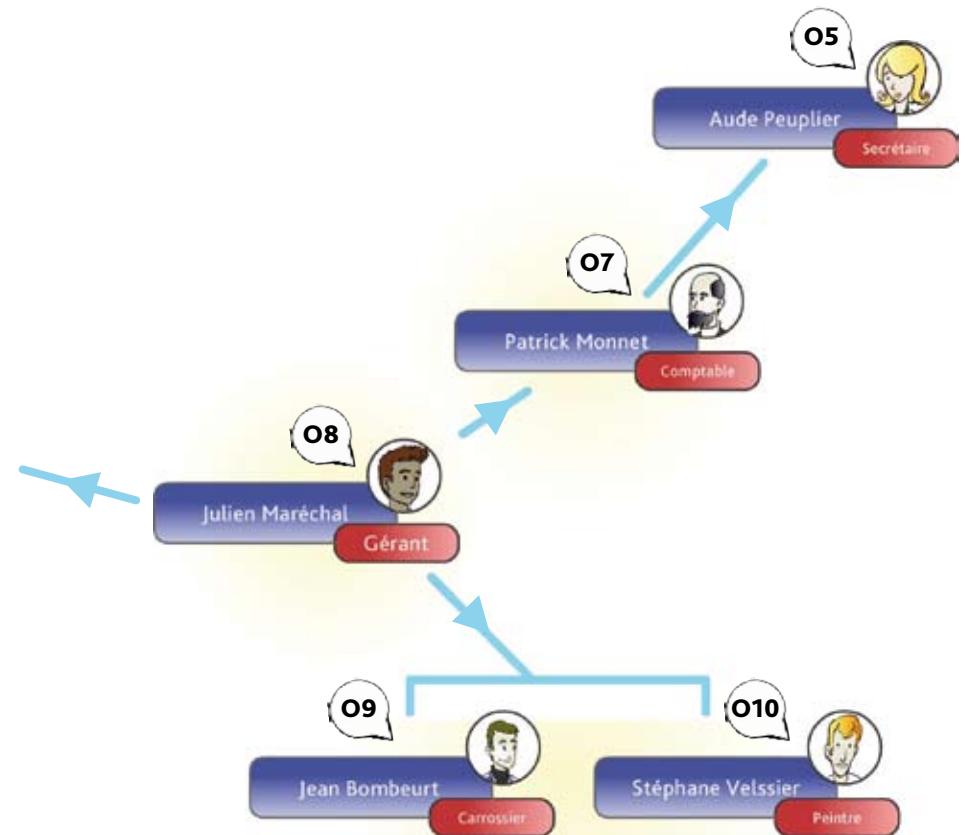

ORGANIZATION CHART

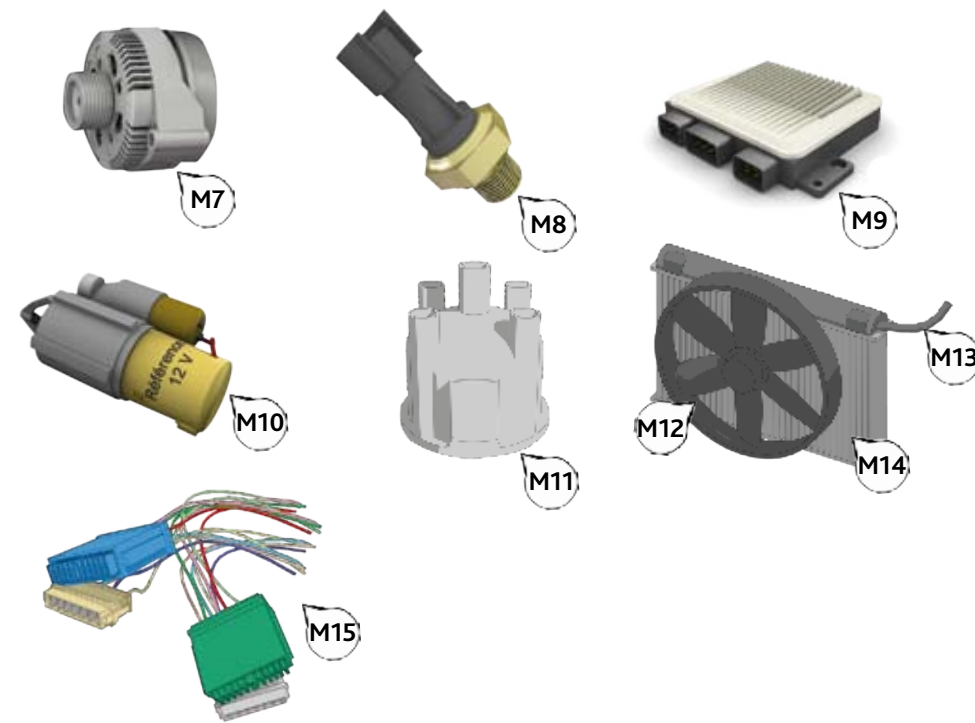
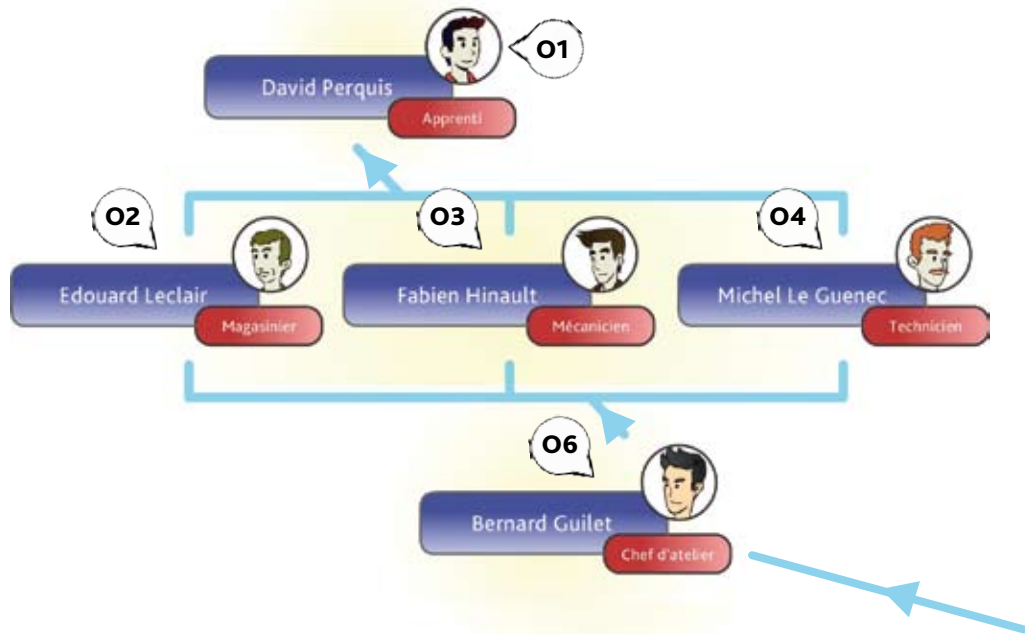

01	A _ _ _ _ _
02	S _ _ _ _ W _ _ _ _
03	M _ _ _ _
04	T _ _ _ _
05	S _ _ _ _
06	W _ _ _ _ M _ _ _ _
07	A _ _ _ _
08	B _ _ _
09	B _ _ _ _
010	P _ _ _ _

M7	A _ _ _ _ _
M8	T _ _ _ _ S _ _ _ _
M9	E _ _ _ _ C _ _ _ _ B _ _
M10	S _ _ _ _
M11	I _ _ _ _
M12	F _ _ M _ _ _
M13	F _ _ _ _ P _ _ _
M14	R _ _ _ _
M15	E _ _ _ _ W _ _ _ _

N [ENGINE]

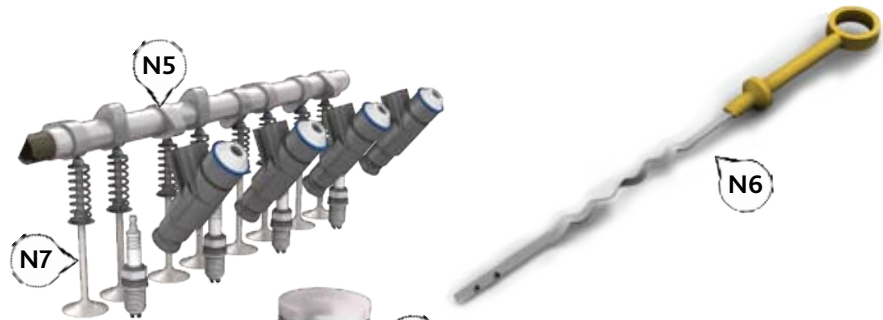
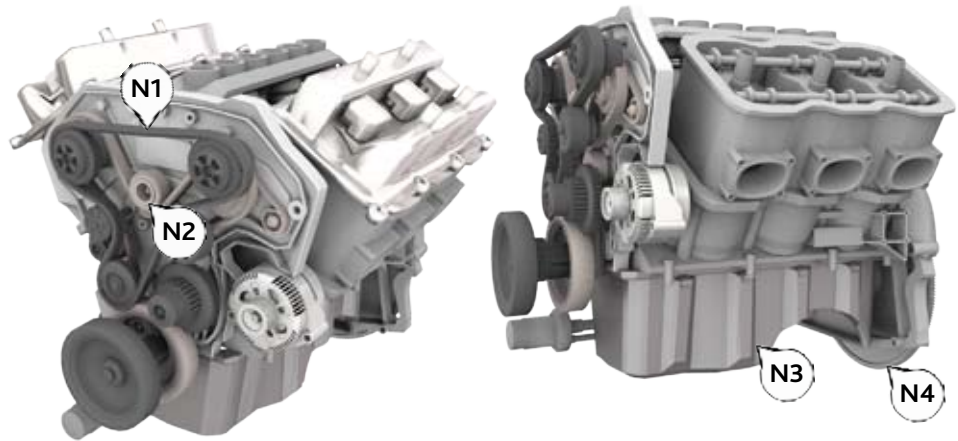

N1	T _ _ _ _ B _ _ _
N2	T _ _ _ _ _ R _ _ _ _
N3	E _ _ _ _ B _ _ _ _
N4	F _ _ _ _ _ _
N5	C _ _ _ _ _
N6	O _ _ G _ _ _ _
N7	V _ _ _ _
N8	P _ _ _ _ _
N9	C _ _ _ _ _ _ _ R _ _
N10	C _ _ _ _ _ _
N11	C _ _ _ _ _ _ _
N12	E _ _ _ _ _
N13	C _ _ _ _ _ C _ _ _ _
N14	W _ _ _ _ P _ _ _

